

Rough Plans for Simple Skinny

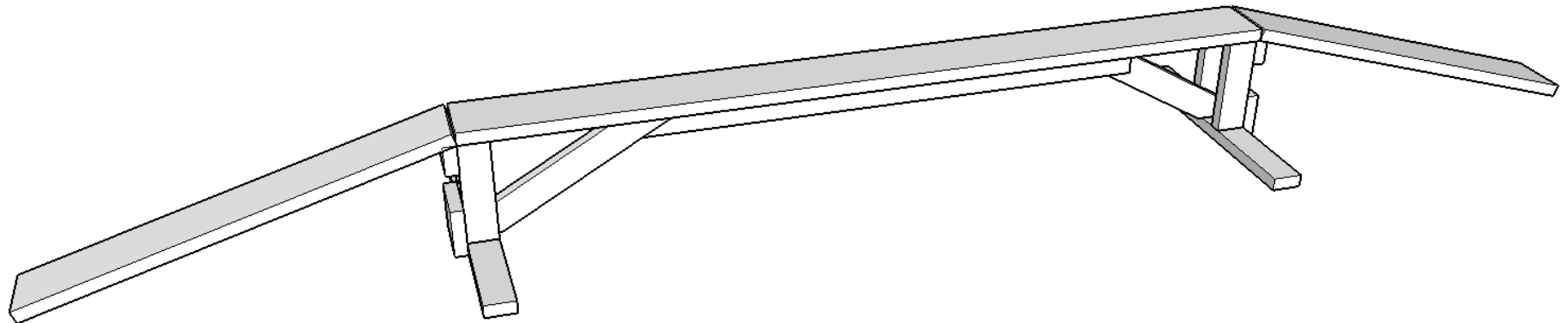

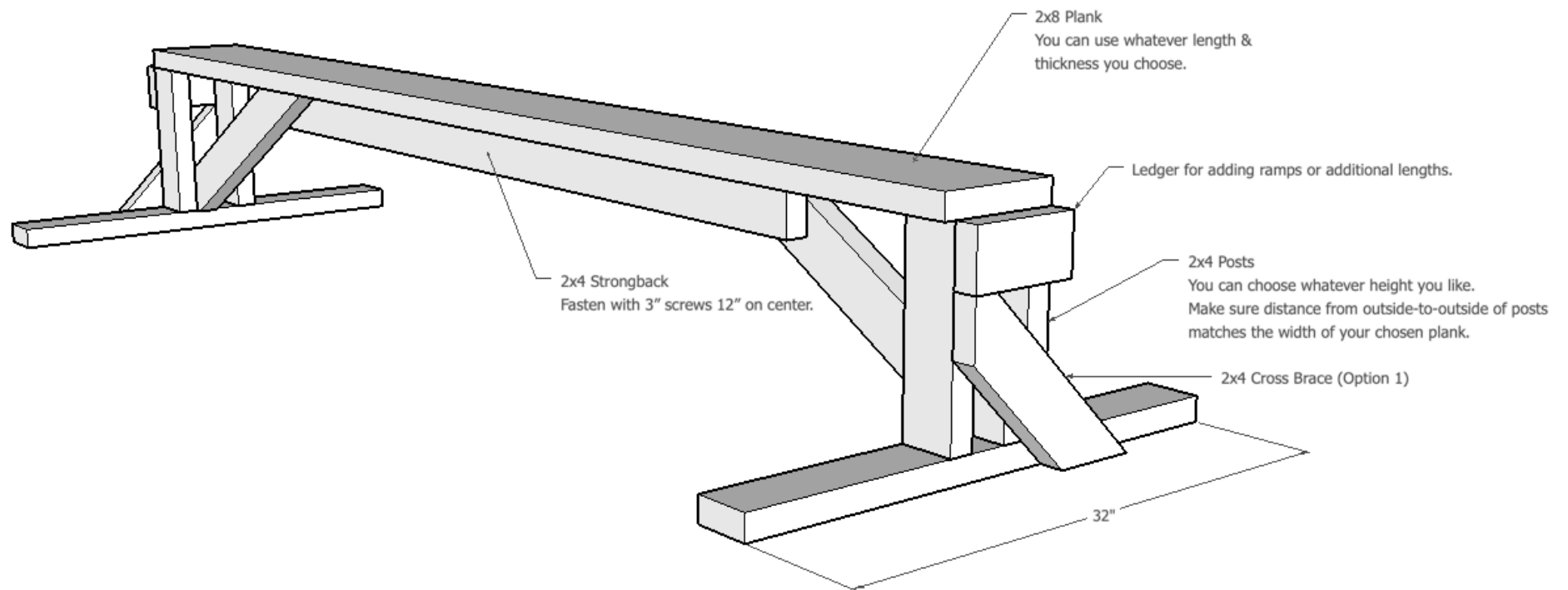

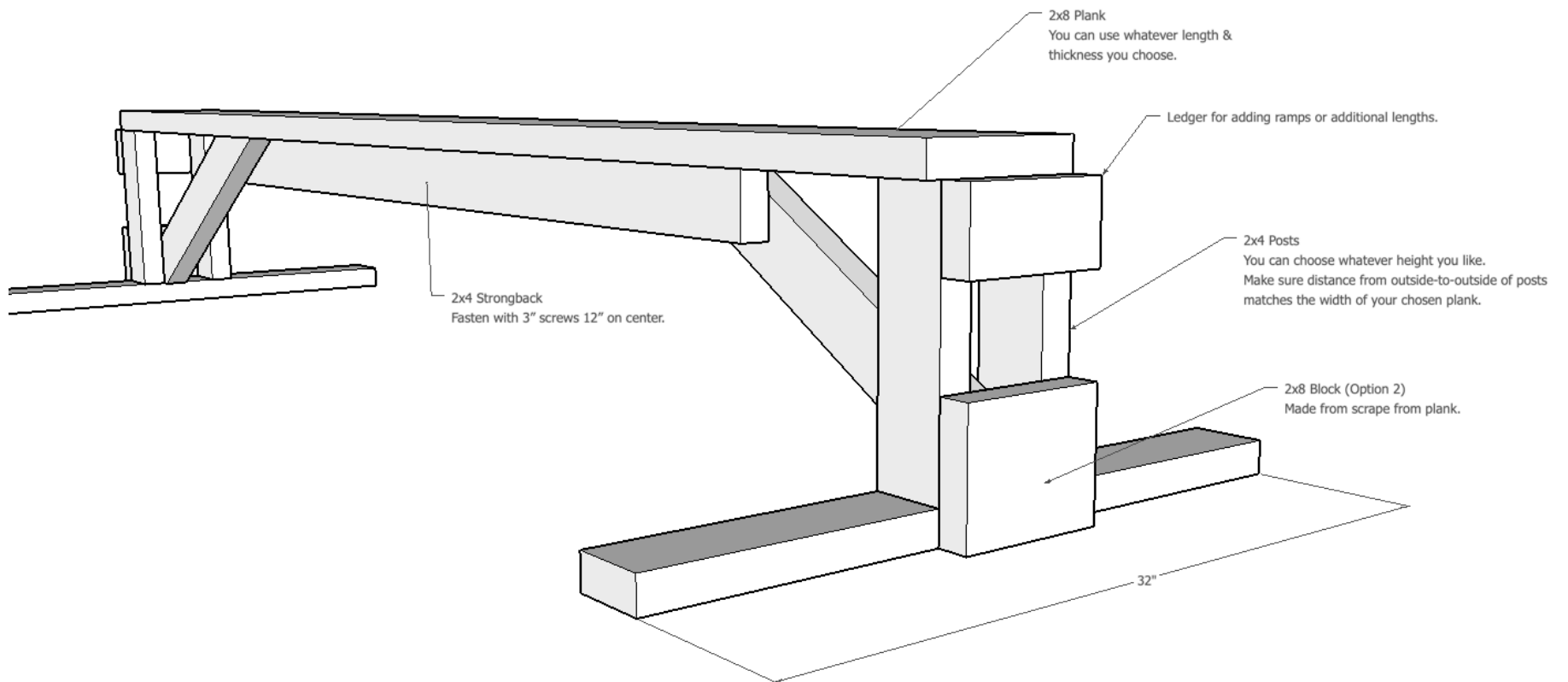

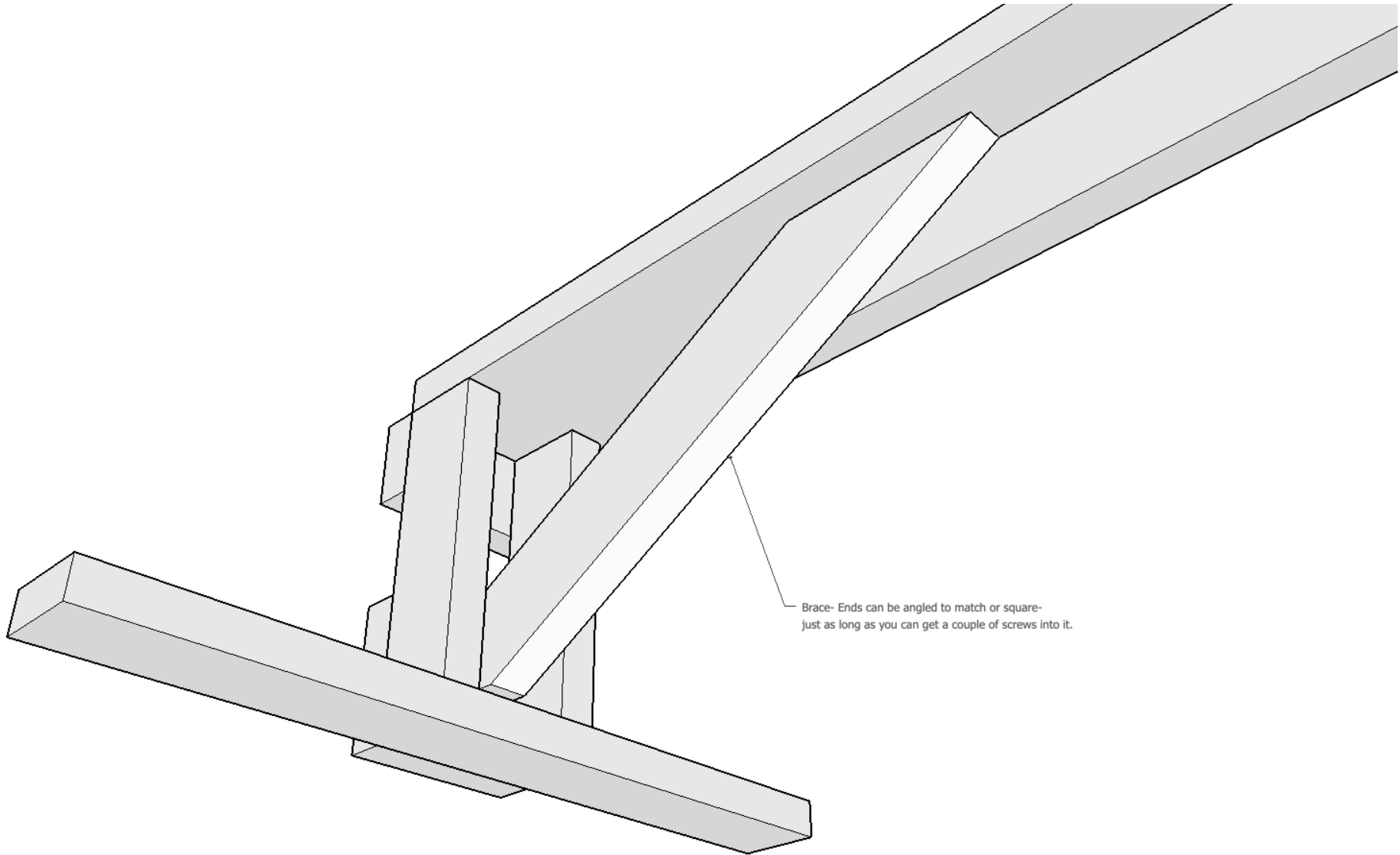

Brace- Ends can be angled to match or square-
just as long as you can get a couple of screws into it.